

Powermax45®

Duramax® hand/machine consumables

The Duramax torch series is an optional torch upgrade for Powermax45 systems. The following are the compatible consumables.



Minimum order quantity		1	1	5	5	1
Consumable type	Torch type	Shield/deflector	Retaining cap	Nozzle	Electrode	Swirl ring
Drag cutting (15–45 A)	Hand	220818 ²	220854	220941 ²	220842 ² or 220777 ^{1,2}	220857
Quantity in kit		2	1	7	7	1
Essential cutting kit – 851510 (15–45 A)	Hand	220818	220854	220941	220842	220857

¹For longer consumable life when cutting metal 1/2 inch (12 mm) and under, check out the CopperPlus electrode (part number 220777).
²Consumable available in bulk packaging. See order information below.



Minimum order quantity		1	1	5	5	1
Consumable type	Torch type	Shield/deflector	Retaining cap	Nozzle	Electrode	Swirl ring
Mechanized (15–45 A)	Machine	220817 ² or 220955 ³	220854 or 220953 ohmic	220941 ²	220842 ² or 220777 ^{1,2}	220857
Quantity in kit		2	1	7	4	3
Essential cutting kit – 851511 or 851512 (ohmic) (15–45 A)	Machine	220817	220955	220941	220842	220777

¹For longer consumable life when cutting metal 1/2 inch (12 mm) and under, check out the CopperPlus electrode (part number 220777).
²Consumable available in bulk packaging. See order information below.
³Deflector for unshielded cutting.



Minimum order quantity		1	1	5	5	1
Consumable type	Torch type	Shield/deflector	Retaining cap	Nozzle	Electrode	Swirl ring
Max control gouging (15–45 A)	Hand/Machine	420480	220854	420419	220842	220857



Minimum order quantity		1	1	5	5	1
Consumable type	Torch type	Shield/deflector	Retaining cap	Nozzle	Electrode	Swirl ring
FineCut® (30–45 A)	Hand	220931	220854 or 220953 (ohmic)	220930 ²	220842 ²	220947
	Machine	220948 (ohmic) 220955				

²Consumable available in bulk packaging. See order information below.



Minimum order quantity		1	1	1	1	
Consumable type	Torch type	Retaining cap	Nozzle	Electrode	Swirl ring	
HyAccess™ drag cutting (30–65 A)	Hand	420413	420410	420408	220857	
HyAccess gouging (30–65 A)			420412			
Quantity in kit		1	1	1	2	1
HyAccess kit – 428414 (30–65 A)	Hand	420413	420410 (cutting)	420412 (gouging)	420408	220857
		HyAccess cutting only starter pack – 428445 ⁴ HyAccess gouging only starter pack – 428446 ⁵				

⁴Starter pack contains 1 retaining cap (420413), 1 cutting nozzle (420410) and 1 electrode (420408)

⁵Starter pack contains 1 retaining cap (420413), 1 gouging nozzle (420412) and 1 electrode (420408)



Minimum order quantity		1	1	1	5	1
Consumable type	Torch type	Retaining cap	Retaining ring	Nozzle/shield assembly	Electrode	Swirl ring
Duramax FlushCut™ (30–45 A) ⁶	Hand/Machine	420536	420540	420633	420635 ⁶	420634
Quantity in kit		1	1	1	1	1
FlushCut kit – 428746	Hand/Machine	420536	420540	420633	420635 ⁶	420634

⁶Not for use with Duramax retrofit torches.

⁶The 45 A FlushCut process will only work with Electrode 420635. The standard 220842 electrodes and 220777 CopperPlus electrodes are not compatible with the 45 A FlushCut process.

Duramax® consumable bulk kits

Order quantity	25	25	25	25	10	10
Bulk kit part number	228934	228767	228761	228765	228763	228764
Contents	220777 electrode	220842 electrode	220930 nozzle	220941 nozzle	220817 shield	220818 shield



Duramax® 75° hand torch parts

For use with the Powermax45® XP, and Powermax65,85/105. The Duramax torch series is an optional torch upgrade for Powermax45 systems.



Duramax 75° hand torch assembly

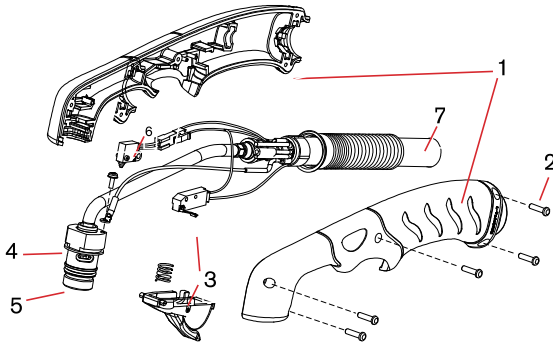

Item	Kit/Part number	Description
	059473	Duramax 75° hand torch assembly with 7.6 m (25') lead
	059474	Duramax 75° hand torch assembly with 15.2 m (50') lead
1	228954	Kit: Duramax 75°/HRT Torch handle replacement
2	075714	Handle screws, #4 x 1/2 slotted TORX pan head, S/B
3	228721	Kit: Duramax 75°/Duramax 15°/HRT/HRTs (spring and trigger assembly)
4	228714	Kit: Duramax 75° Torch main body replacement (3/8" coupler)
4	228958	Kit: Duramax 75° Torch main body replacement (1/2" coupler)
5	058519	O-ring
6	228719	Kit: Duramax 75° Cap-sensor switch replacement
7	228959	Kit: Duramax 75° Torch lead replacement, 7.6 m (25')
7	228960	Kit: Duramax 75° Torch lead replacement, 15.2 m (50')
	228300	Work lead with clamp, 6.1 m (20')
	228307	Work lead with clamp, 15.2 m (50')

Duramax® 15° hand torch parts

For use with the Powermax45® XP, and Powermax65,85/105. The Duramax torch series is an optional torch upgrade for Powermax45 systems.

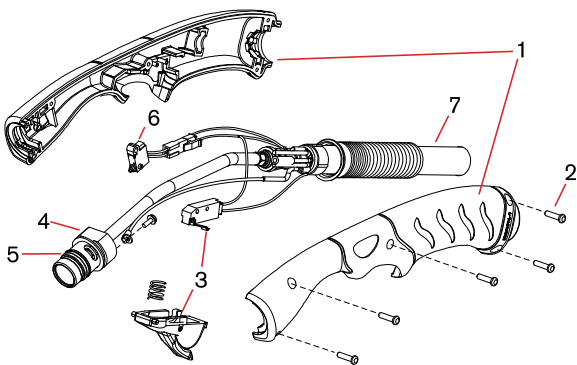

Duramax 15° hand torch assembly

Item	Kit/Part number	Description
	059470	Duramax 15° hand torch assembly with 7.6 m (25') lead
	059471	Duramax 15° hand torch assembly with 15.2 m (50') lead
1	228955	Kit: Duramax 15° Torch handle replacement
2	075714	Handle screws, #4 x 1/2 slotted TORX pan head, S/B
3	228721	Kit: Duramax 15°/Duramax 75°/HRT/HRTs (spring and trigger assembly)
4	228715	Kit: Duramax 15° Torch main body replacement (3/8" coupler)
4	228957	Kit: Duramax 15° Torch main body replacement (1/2" coupler)
5	058519	O-ring
6	228109	Kit: Duramax 15° Cap-sensor switch replacement
7	228959	Kit: Duramax 15° Torch lead replacement, 7.6 m (25')
7	228960	Kit: Duramax 15° Torch lead replacement, 15.2 m (50')
	228300	Work lead with clamp, 6.1 m (20')
	228307	Work lead with clamp, 15.2 m (50')

Duramax® 180° machine torch parts

For use with the Powermax45® XP, and Powermax65/85/105. The Duramax torch series is an optional torch upgrade for Powermax45 systems.

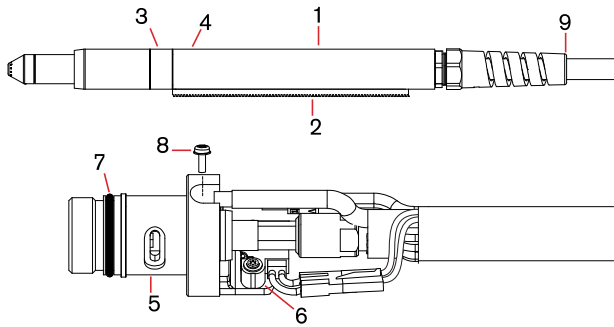

Duramax 180° machine torch assembly

Item	Kit/Part number	Description
	059476	Duramax 180° machine torch assembly with 4.5 m (15') lead
	059477	Duramax 180° machine torch assembly with 7.6 m (25') lead
	059478	Duramax 180° machine torch assembly with 10.7 m (35') lead
	059479	Duramax 180° machine torch assembly with 15.2 m (50') lead
1	228737	Kit: Duramax 180° positioning sleeve
2	228738	Kit: Duramax 180° removable gear rack
3	228735	Kit: Duramax 180°/Duramax 180° torch front mounting sleeve
4	228736	Kit: Duramax 180°/Duramax 180° torch adapter ring (coupler)
5	228716	Kit: Duramax 180°/Duramax 180° torch main body replacement
6	228720	Kit: Cap-sensor switch replacement
7	058519	O-ring
8	075504	Pilot terminal screw
9	228730	Kit: Duramax 180°/Duramax 180° torch lead replacement, 4.5 m (15')
9	228731	Kit: Duramax 180°/Duramax 180° torch lead replacement, 7.6 m (25')
9	228732	Kit: Duramax 180°/Duramax 180° torch lead replacement, 10.7 m (35')
9	228733	Kit: Duramax 180°/Duramax 180° torch lead replacement, 15.2 m (50')
	228300	Work lead with clamp, 6.1 m (20')
	228307	Work lead with clamp, 15.2 m (50')

Duramax® 180° mini machine torch parts

For use with the Powermax45® XP, and Powermax65/85/105. The Duramax torch series is an optional torch upgrade for Powermax45 systems.

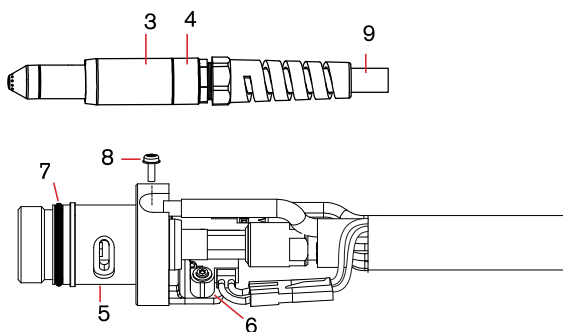

Duramax 180° mini torch assembly

Item	Kit/Part number	Description
	059481	Duramax 180° mini machine torch assembly with 4.5 m (15') lead
	059482	Duramax 180° mini machine torch assembly with 7.6 m (25') lead
	059483	Duramax 180° mini machine torch assembly with 10.7 m (35') lead
3	220956	Kit: Duramax 180°/Duramax 180° mini torch front mounting sleeve
4	220808	Kit: Duramax 180°/Duramax 180° mini torch adapter ring (coupler)
5	228716	Kit: Duramax 180°/Duramax 180° mini torch main body replacement
6	228720	Kit: Cap-sensor switch replacement
7	058519	O-ring
8	075504	Pilot terminal screw
9	228730	Kit: Duramax 180°/Duramax 180° mini torch lead replacement, 4.5 m (15')
9	228731	Kit: Duramax 180°/Duramax 180° mini torch lead replacement, 7.6 m (25')
9	228732	Kit: Duramax 180°/Duramax 180° mini torch lead replacement, 10.7 m (35')
9	228733	Kit: Duramax 180°/Duramax 180° mini torch lead replacement, 15.2 m (50')
	228300	Work lead with clamp, 6.1 m (20')
	228307	Work lead with clamp, 15.2 m (50')

Duramax® 180° robotic torch parts

For use with the Powermax45® XP, and Powermax65/85/105. The Duramax torch series is an optional torch upgrade for Powermax45 systems.

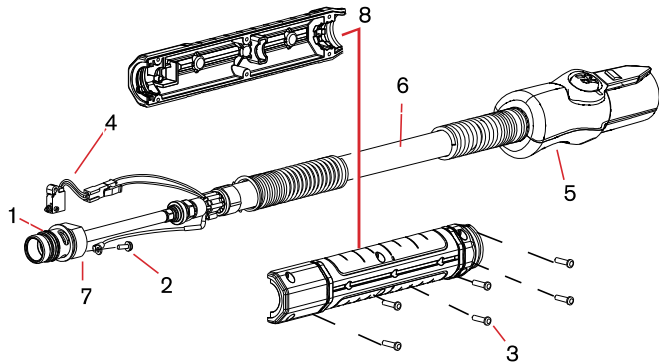

Duramax 180° robotic torch assembly

The entire Duramax 180° robotic torch assembly with leads can be replaced, or individual component parts can be replaced.

Item	Kit/Part number	Description
	059466	180° Duramax robotic torch assembly with leads
	059587	180° Duramax robotic torch assembly with 15.2 m (50') lead
1	058519	O-ring
2	075504	Pilot terminal screw
3	075714	#4 x 1/2 slotted TORX pan head screws
4	228109	Kit: Cap-sensor switch replacement
5	428260	Kit: FastConnect replacement
6	228852	Kit: Robotic torch lead replacement, 7.6 m (25')
7	228853	Kit: 180° Robotic torch main body replacement
8	228856	Kit: 180° Robotic torch positioning barrel replacement
	228806	Kit: Robotic torch clamp assembly

Duramax® 90° robotic torch parts

For use with the Powermax45®

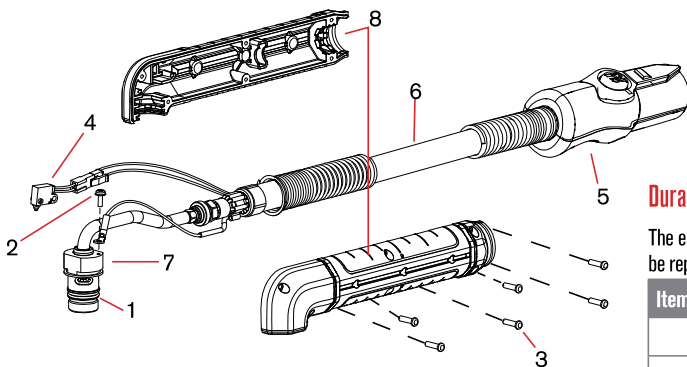

Duramax 90° robotic torch assembly

The entire Duramax 90° robotic torch assembly with leads can be replaced, or individual component parts can be replaced.

Item	Kit/Part number	Description
	059465	90° Duramax robotic torch assembly with leads
	059586	90° Duramax robotic torch assembly with 15.2 m (50') lead
1	058519	O-ring
2	075504	Pilot terminal screw
3	075714	#4 x 1/2 slotted TORX pan head screws
4	228109	Kit: Cap-sensor switch replacement
5	428260	Kit: FastConnect replacement
6	228852	Kit: Robotic torch lead replacement, 7.6 m (25')
7	228854	Kit: 90° Robotic torch main body replacement
8	228857	Kit: 90° Robotic torch positioning barrel replacement
	228806	Kit: Robotic torch clamp assembly

Duramax® 45° robotic torch parts

For use with the Powermax45® XP, and Powermax65,85/105. The Duramax torch series is an optional torch upgrade for Powermax45 systems.

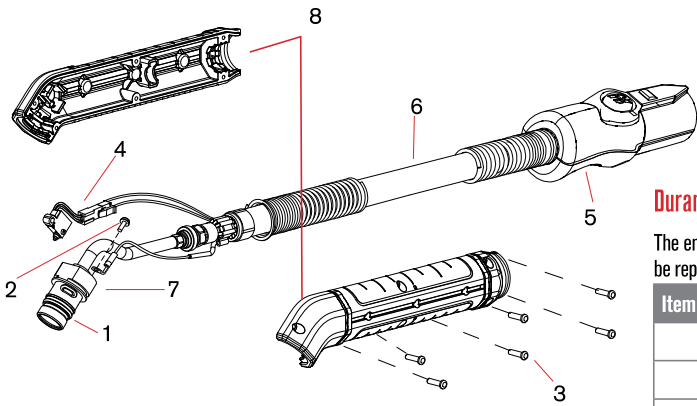

Duramax 45° robotic torch assembly

The entire Duramax 45° robotic torch assembly with leads can be replaced, or individual component parts can be replaced.

Item	Kit/Part number	Description
	059464	45° Duramax robotic torch assembly with leads
	059585	45° Duramax robotic torch assembly with 15.2 m (50') lead
1	058519	O-ring
2	075504	Pilot terminal screw
3	075714	#4 x 1/2 slotted TORX pan head screws
4	228109	Kit: Cap-sensor switch replacement
5	428260	Kit: FastConnect replacement
6	228852	Kit: Robotic torch lead replacement, 7.6 m (25')
7	228855	Kit: 45° Robotic torch main body replacement
8	228858	Kit: 45° Robotic torch positioning barrel replacement
	228806	Kit: Robotic torch clamp assembly